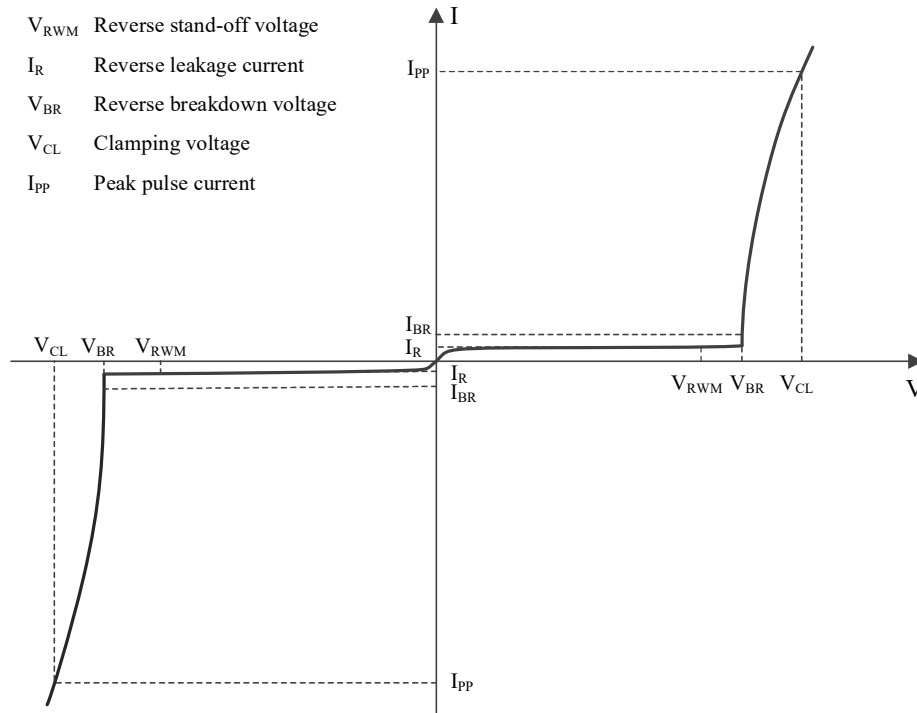

MARKING (TOP VIEW)

T = Device code
M = Data code (A~Z)

LIMITING VALUES

Parameter	Symbol	Value	Unit
Peak pulse power ($t_p=8/20\mu s$)	P_{pk}	259	W
Peak pulse current ($t_p = 8/20\mu s$)	I_{PP}	7	A
ESD according to IEC61000-4-2 air discharge	V_{ESD}	± 30	kV
ESD according to IEC61000-4-2 contact discharge		± 30	kV
ESD according to ISO 10605 contact discharge C = 330 pF, R = 330 Ω ; C = 150 pF, R = 330 Ω ; C = 330 pF, R = 2 k Ω ; C = 150 pF, R = 2 k Ω		± 30	kV
Junction temperature	T_J	150	$^{\circ}C$
Operating temperature	T_{OP}	-55~150	$^{\circ}C$
Lead temperature	T_L	260	$^{\circ}C$
Storage temperature	T_{STG}	-65~150	$^{\circ}C$

ELECTRICAL CHARACTERISTICS

Definitions of electrical characteristics

Parameter	Symbol	Conditions	Min	Typ	Max	Unit
Reverse maximum working voltage	V_{RWM}				± 24	V
Reverse leakage current	I_R	$V_{RWM} = 24V$			50	nA
Reverse breakdown voltage	V_{BR}	$I_T = 1mA$		28		V
Clamping voltage ⁽¹⁾	V_{CL}	$I_{PP} = 16A, t_p = 100ns$		31		V
Dynamic resistance ⁽¹⁾	R_{DYN}			0.15		V
Clamping voltage ⁽²⁾	V_{CL}	$V_{ESD} = 8kV$		34		V
Clamping voltage ⁽³⁾	V_{CL}	$I_{PP} = 1A, t_p = 8/20\mu s$		30		V
		$I_{PP} = 7A, t_p = 8/20\mu s$		37		Ω
Junction capacitance	C_J	$V_R = 0V, f = 1MHz$		25	30	pF

($T_A = 25^\circ C$, unless otherwise noted.)

(1) TLP parameter: $Z_0 = 50\Omega$, $t_p = 100ns$, averaging window from 70ns to 90ns. R_{DYN} is calculated from 4A to 16A.

(2) Contact discharge mode, according to IEC61000-4-2.

(3) Non-repetitive current pulse, according to IEC61000-4-5.

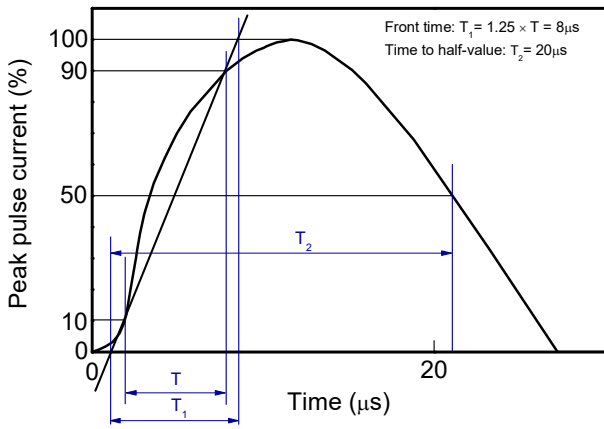
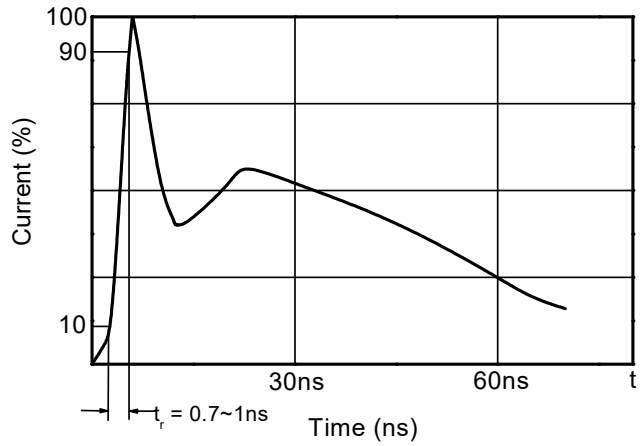
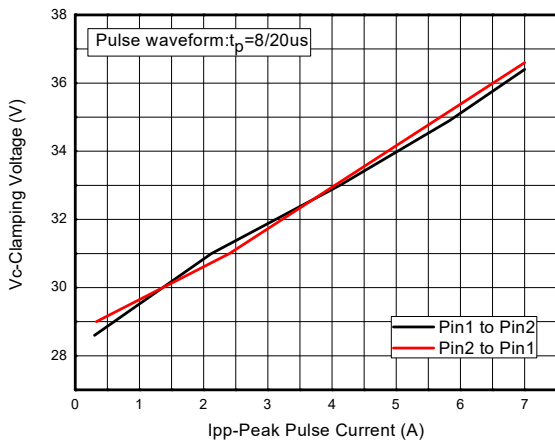
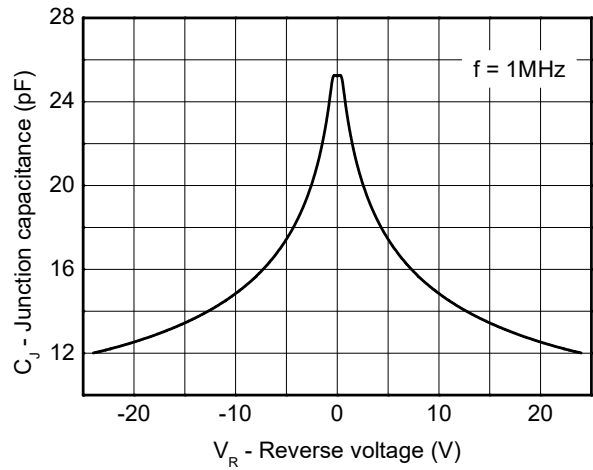
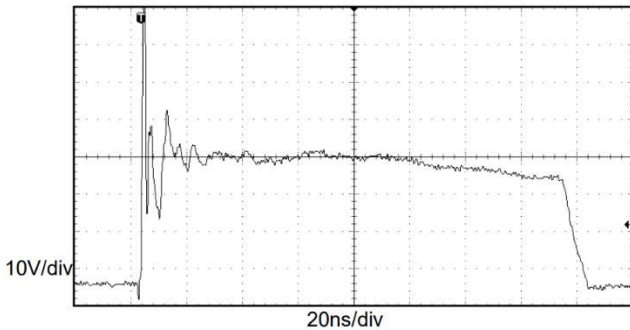
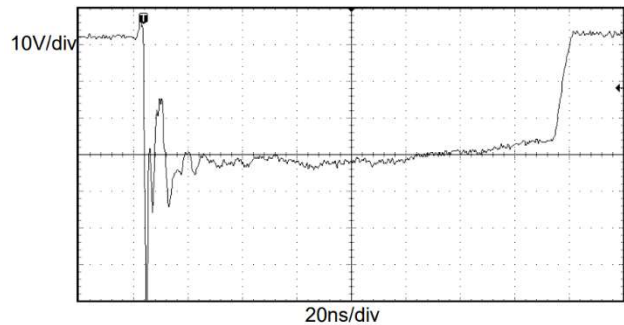
TYPICAL CHARACTERISTICS

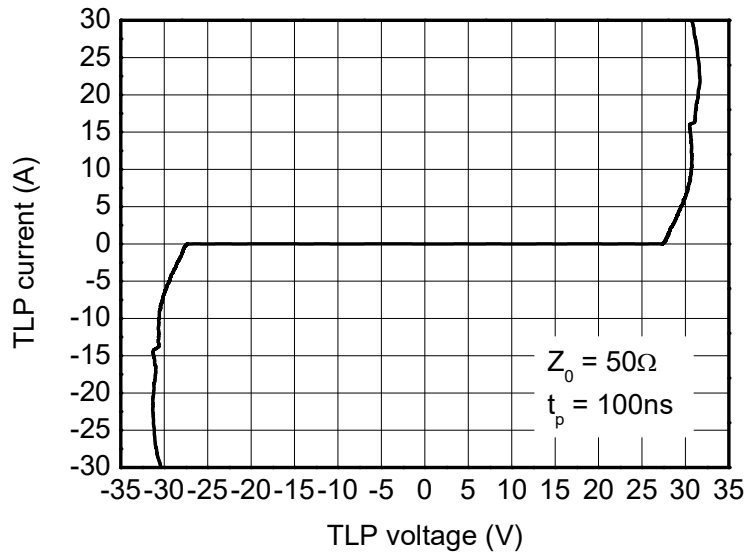
8/20μs waveform per IEC61000-4-5

Contact discharge current waveform per IEC61000-4-2

Clamping voltage vs. Peak pulse current

Capacitance vs. Reverse voltage

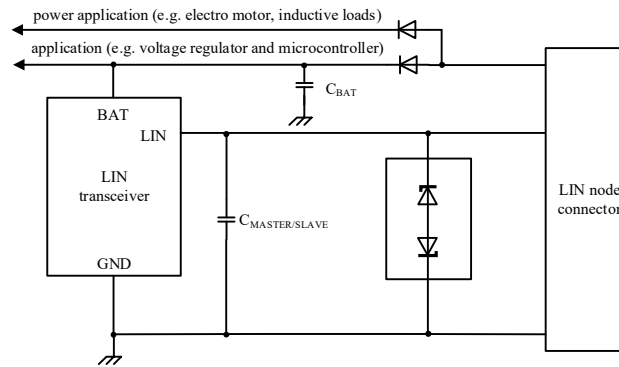
ESD clamping
(+8kV contact discharge per IEC61000-4-2)

ESD clamping
(-8kV contact discharge per IEC61000-4-2)



TLP Measurement

APPLICATION INFORMATION

The SITNW24V1BNQ is designed for the protection of one LIN-bus signal line from the damage caused by ESD and surge pulse. The SITNW24V1BNQ provides a surge capability of up to 259W per line for a 8/20 μ s waveform.



Typical application: ESD protection of one automotive LIN-bus line

Circuit board layout and protection device placement

Circuit board layout is critical for the suppression of ESD, Electrical Fast Transient (EFT) and surge transients. The following guidelines are recommended:

1. Place the SITNW24V1BNQ as close to the input terminal or connector as possible.
2. The path length between the SITNW24V1BNQ and the protected line should be minimized.
3. Keep parallel signal paths to a minimum.
4. Avoid running protection conductors in parallel with unprotected conductor.
5. Minimize all Printed-Circuit Board (PCB) conductive loops including power and ground loops.
6. Minimize the length of the transient return path to ground.
7. Avoid using shared transient return paths to a common ground point.
8. Ground planes should be used whenever possible. For multilayer PCBs, use ground vias.

SOD-323 DIMENSIONS
PACKAGE SIZE

Symbol	Min.	Typ.	Max.
A	-	-	1.35
A1	0.80	-	1.15
A2	0.00	-	0.20
b	0.25	-	0.40
c	0.08	-	0.18
D1	1.40	1.60	1.80
D	2.30	2.55	2.80
E	1.15	-	1.40
L	0.48Ref.		
L1	0.10	-	0.50
θ	0°	-	8°

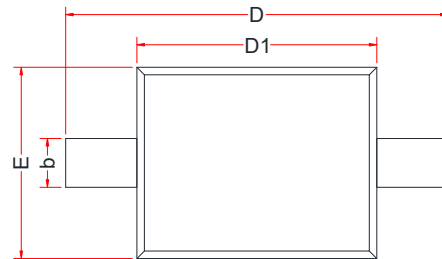

BOTTOM VIEW

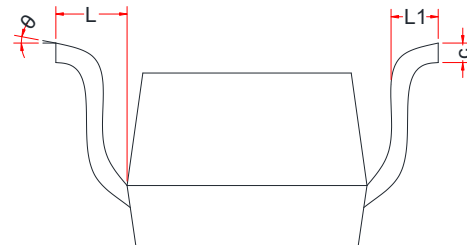

SIDE VIEW

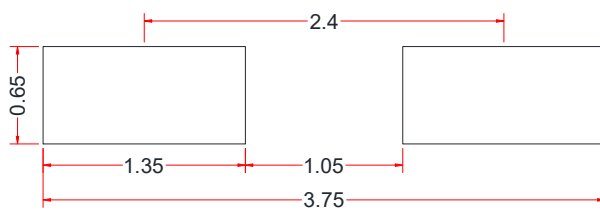

RECOMMENDED LAND PATTERN (Unit:mm)

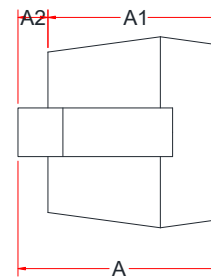

SIDE VIEW

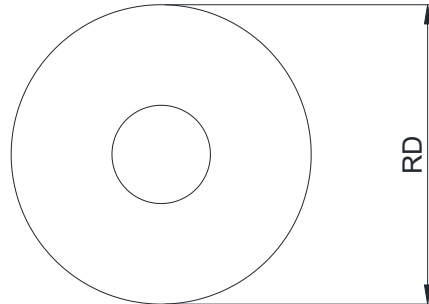
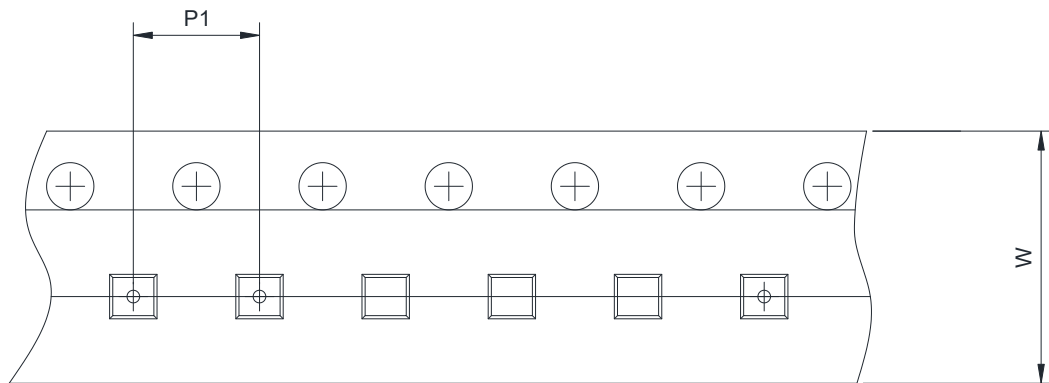
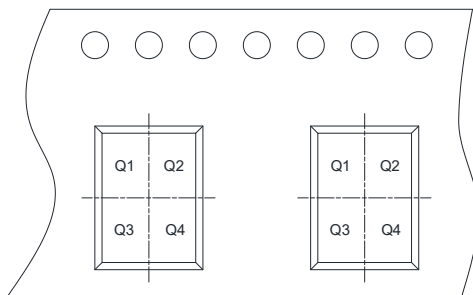
TAPE AND REEL INFORMATION
Reel Dimensions

Tape Dimensions

Quadrant Assignments For PIN1 Orientation In Tape



 User Direction of Feed

RD	Reel Dimension	<input checked="" type="checkbox"/> 7inch	<input type="checkbox"/> 13inch
W	Overall width of the carrier tape	<input checked="" type="checkbox"/> 8mm	<input type="checkbox"/> 12mm <input type="checkbox"/> 16mm
P1	Pitch between successive cavity centers	<input type="checkbox"/> 2mm	<input checked="" type="checkbox"/> 4mm <input type="checkbox"/> 8mm
Pin1	Pin1 Quadrant	<input checked="" type="checkbox"/> Q1	<input checked="" type="checkbox"/> Q2 <input type="checkbox"/> Q3 <input type="checkbox"/> Q4

ORDERING INFORMATION

TYPE NUMBER	PACKAGE	PACKING
SITNW24V1BNQ-2/TR	SOD-323	Tape and reel

SOD-323 is packed with 3000 pieces/disc in braided packaging.

Important statement

SIT reserves the right to change the above-mentioned information without prior notice.

REVISION HISTORY

Version number	Datasheet status	Revision date
V1.0	Initial version.	November 2023